

Model 450 SHAFT RIDER FOR IRD BALANCING SENSORS

IRD Shaft Riders for sensors are used for measuring vibration of a rotating shaft by coupling the sensor directly to the shaft surface. On large rotating machines with rather massive rotors, a measure of “absolute” shaft vibration (relative to a fixed point in space) is preferred for monitoring machine condition and for in-place dynamic balancing.

The IRD Shaft Rider is provided for obtaining absolute shaft vibration measurements. A rod with a long-wearing non-metallic tip is firmly held against the rotating shaft to accurately follow shaft motion. A sensor mounted to the shaft rider provides an electrical output proportional to the absolute shaft vibration.

Applications for the Shaft Rider include all large rotating machines where shaft surface speeds are moderate. Shaft Riders are installed within the bearing area to provide tip lubrication. A mechanical stop prevents the Shaft Rider from marring or scoring the shaft as the rider tip wears, and a visible indicator provides assurance of proper installation as well as a check of tip wear.

Many rod lengths are available with provisions for mounting sensors.

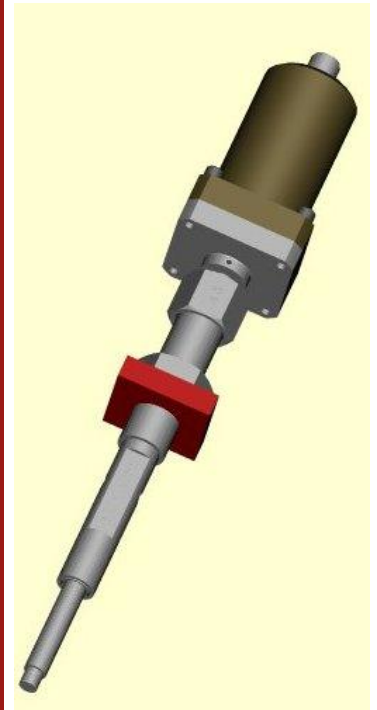

Line Drawing:

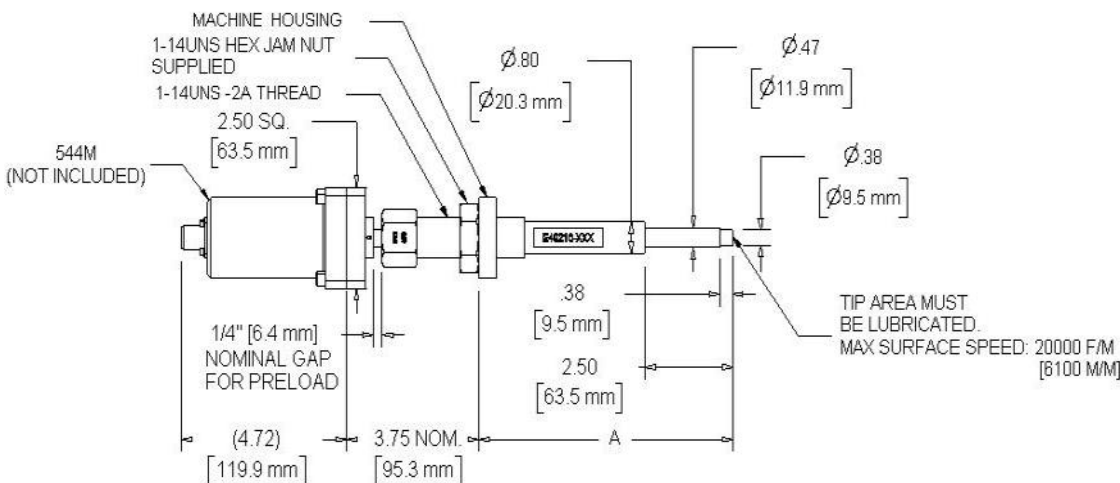

Shaft Rider

Model 450

SHAFT RIDER FOR IRD BALANCING SENSORS

GENERAL SPECIFICATIONS

Frequency Range	With Model 544M, 15-180 Hz flat within $\pm 5\%$
Amplitude Range	Up to 5g (equivalent to 25 mils pk-pk at 3600 RPM) with 12 pounds preload
Temperature Range	-40° to 350° F (-40° to 176° C) - Shaft Rider only
Mounting	Through 1-14 threaded hole; length adjustable $\pm 3/4$ inch

ORDERING INFORMATION FOR MODEL 450 SHAFT RIDERS

Part Number	Description	Dimension A
E49210-050	ASM, M450 SHAFT RIDER 3.5"-5"	3.5 - 5"
E49210-065	ASM, M450 SHAFT RIDER 5"-6.5"	5 - 6.5"
E49210-080	ASM, M450 SHAFT RIDER 6.5"-8"	6.5 - 8"
E49210-095	ASM, M450 SHAFT RIDER 8"-9.5"	8 - 9.5"
E49210-110	ASM, M450 SHAFT RIDER 9.5"-11"	9.5 - 11"
E49210-125	ASM, M450 SHAFT RIDER 11"-12.5"	11 - 12.5"
E49210-140	ASM, M450 SHAFT RIDER 12.5"-14"	12.5 - 14"
E49210-155	ASM, M450 SHAFT RIDER 14"-15.5"	14 - 15.5"
E49210-170	ASM, M450 SHAFT RIDER 15.5"-17"	15.5 - 17"
E49210-185	ASM, M450 SHAFT RIDER 17"-18.5"	17 - 18.5"
E49210-200	ASM, M450 SHAFT RIDER 18.5"-20"	18.5 - 20"

Optional Accessory

E21117-1	SHAFT RIDER TIP, 3/8"DIA WITH MOUNTING PIN
----------	--

USA Headquarters:

IRD LLC

UK:

IRD UK Ltd.

MEXICO:

IRD Balancing México

CANADA:

IRD Canada Ltd.

Telephone: (1) 502 366 0916 Fax: (1) 502 238 1001

4740 Allmond Ave. Louisville, KY 40209, USA

Telephone: +44 1244 538170 Fax: +44 1244 528900

International House, Aviation Park, Flint Road, Saltney Ferry, Chester UK CH4 0GZ

Telephone: +52.55.5689.8325 Fax: +52 55.5689.8160

S. de R. L. de C.V.; Miguel G. Kramer #29, Col. Atlántida Del. Coyoacán, México, D. F.C.P. 04370

Telephone: 1.450.724.4066 Fax: 1.450.724.4077

755 Jean-Baptiste-Varin, La Prairie, QC J5R 6P3, Canada

Specifications are subject to change without prior notice.

Copyright © 2011IRD®
All rights reserved.

Publication No: E51354
Rev 1, 7 February 2011