

B Series – B200F

11000 kg (25000 lb) Capacity

User Fabricated Balancing Machine



HORIZONTAL AXIS, GENERAL PURPOSE, SOFT BEARING, BALANCING MACHINE

DESCRIPTION:

The B200F is a dynamic, horizontal axis, soft bearing Balancing Machine that is assembled with precision balancing parts supplied by IRD and others supplied or fabricated by the user. IRD supplies two modular suspension work supports, two sets of roller work supports, drive motor pulley, idler pulleys, belts, end thrusts and fabrication drawings. The customer supplies a machine bed, pedestals for mounting the modular suspension work supports, the drive motor, variable speed motor controller and a frame for the belt drive. Optional instrument packages, V-Block rotor work supports, drive power systems and negative load hold downs are available.

GENERAL SPECIFICATIONS:

- Weight Capacity: 11000 kg (25000 lb)
- Max. Rotor Diameter: 2800 mm (110 inches)
- Maximum Sensitivity: 14.5 g mm (0.6 g in)
- Standard Bed Length: 3350 mm (132 inches)
(User Fabricated)
- Journal Diameter Range: 76-610 mm (3-24 inches)
- Journal-to-Journal Separation: 660 - 2950 mm (26-116 inches)
(Based on User Fabricated Railroad Track Bed)
- Drive Type: Underslung Belt Drive with manual belt tensioning
(User Fabricated- Idler Pulleys by IRD)
- Drive Motor Recommended: DC 18.6kW (25 HP) Variable speed
(User Supplied)
- Balancing Speed Range: 250 to 6000 RPM
(Depends on Driven Rotor Diameter)
- Number of Balance Planes: 1 or 2
- Standard Parts Included: (4) Flat drive belts, (2) roller work supports, (2) modular suspension work supports with motion locks, height adjustment assembly, (2) end thrust assemblies, drive motor pulley with (3) different shaft mounting bushings, (2) idler pulley assemblies and fabrication drawings.
- User Fabricated or Supplied Parts: Fabricate the machine bed and pedestal support frames. Provide the drive system (motor, controls, belt drive frame).

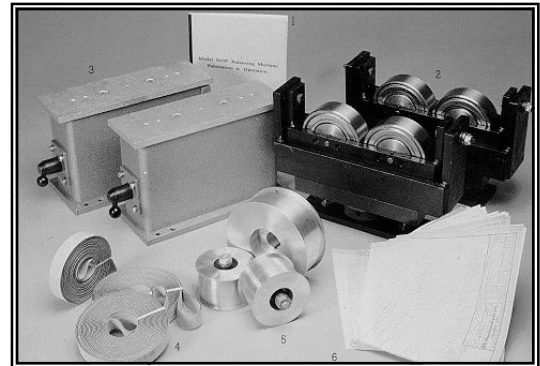

B200F Kit of Parts, typical

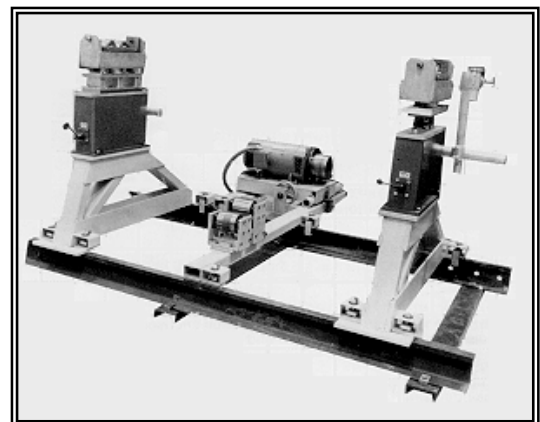

Typical User Fabricated Machine

- General configuration (without rotor):
Dim: 4826 x 2820 x 1625 mm (l x w x h)
(190 x 111 x 64 in) (l x w x h)
- Kit Weight: 490 kg (1100 lb)

OPTIONAL FEATURES:

- Rotor Safety Hold Downs
- V-Block Rotor Work Supports
- Negative Load Hold Downs
- 236 Digital Balancing Instrument
- 246 Portable Balancing Instrument
- 290 Touch Screen Balancing Computer
- Drive motor/controller

STANDARD CONFIGURATIONS:

B200F Basic Machine	Brief Description	Detailed Description
E43072	Complete B200F Balancing Machine kit for motors with 34.9mm/1.375", 41.3mm/1.625" or 47.6mm/1.875" diameter shafts.	Complete B200F Balancing Machine kit includes modular suspension work supports, roller work supports, height adjustment assembly, fixed height assembly, belts, idler pulley assemblies, drive pulley with (3) bushings for different diameter bores, end thrust assemblies and fabrication drawings. This does not include a balancing instrument.

E43072 includes	
E12442	Flat drive belt, 51mm wide x 5537mm long (2 x 218 in)
E12443	Flat drive belt, 51mm wide x 6147mm long (2 x 242 in)
E12444	Flat drive belt, 51mm wide x 6756mm long (2 x 266 in)
E12445	Flat drive belt, 51mm wide x 7366mm long (2 x 290 in)
E07600	Modular Suspension Work Supports, 2 included
E07725	Roller Work supports, with 127mm diax68mm wide rollers (5x2.69 in), 2 included
E07951	Height adjustment (76mm/3in) module for E07725 roller work support.
E08102	Fixed height module for E07725 roller work support
E36240	End thrust assemblies, 2 included
E09679	152 mm diameter (6") idler pulley, 2 included
E46543	203 mm diameter (8") motor drive pulley with bushing for 47.6mm/1.875 in bore motor shaft.
	Additional drive pulley bushings: E30064 for 34.9mm / 1.375" bore and E35034 for 41.3mm/1.625" bore.
E09367	Fabrication drawings
E09782	Operation/Fabrication manual for B200F Balancing System
Balancing Instrument Options	
E00303	Model 236 Digital Balancing Instrument with all accessories needed for balancing. Includes the 236 Balancing Instrument, two 546DP (direct prod) vibration sensors with brackets and magnetic tips, photoelectric speed sensor, reflective tape and all cables.
E00310	Model 246 Portable Balancing Instrument with all accessories needed for balancing. Includes the 246 Balancing Instrument, two 546DP (direct prod) vibration sensors with brackets and magnetic tips, photoelectric speed sensor, reflective tape and all cables.
E00577	Model 290 Touch Screen Balancing Computer with all accessories needed for balancing. Includes the 290 Balancing Instrument, two 546DP (direct prod) vibration sensors with brackets and magnetic tips, photoelectric speed sensor, reflective tape and all cables.

Other Options, Accessories, and Supplies	
E12060	Rotor safety hold down with counter roller, 2 recomnd'd
E09144	V-block Rotor Work Supports, 2 recommended
E32354	V Block mounting assembly with pivoting for use with V-block, E09144
E14428	Negative load hold down assembly for rotors with an outboard center of gravity.
E11713	Replacement roller for standard E07725 roller work support, 127mm diax68 mm W, 2 req'd per work support.
E11698	Lower weight capacity roller work supports, 7000 kg/15000 lb per pair with 100mm dia x 49mmW rollers.
E48674	Railroad track bed assembly, 3353mm L x 280mm H (132 x 11in)
E45989	18.6 kW (25 HP) Motor/Console Assembly. Includes a 2500 RPM DC motor with 1.875" dia. shaft, 5.25: centerline height, angular location sensor, 5.2m/17' flex conduit connected to a 1067mm/42" high control console with a variable speed regenerative braking drive controller mounted inside, operator control panel and circuit breaker; wired for 460VAC, 3-phase operation. Specify 60 or 50 Hz on order.
E02785	546DP Vibration sensor- no magnetic tip or mtg. bracket
E10170	Magnetic tip for 546DP vibration sensor
E11194	546DP Vibration sensor, magnetic tip and mtg. bracket kit
E21000	Photoelectric speed sensor, standard, reflective tape trigger, 25-610 mm (1-24 in) range
E21200	Reflective tape for use with speed sensor, 47.5m (150 ft)
E11820	Balancing wax, sold by the pound
E32147	Epoxy balancing weight compound kit, 2 lb package
E04753	Balancing weights, set of 16, C-shaped with set screw
E11946	Balancing clips for squirrel cage fans (7 sizes of 100 ea)

web: www.irdbalancing.com

email: sales@irdbalancing.com

IRD Balancing Offices (IRD LLC)

USA: Global Headquarters and Factory- IRD LLC, 4740 Allmond Ave, Louisville, KY 40209 USA

Tel: (1) 502 366 0916 or (1) 888 473 2251 (US Toll Free)

Fax: (1) 502 238 1001

Europe/UK: IRD UK Ltd, International House, Aviation Park, Flint Road, Saltney Ferry, Chester CH4 0GZ, UK

Tel: +44 (0) 1244 538 170

Fax: +44 (0) 1244 528 900

Mexico: IRD Balancing-Mexico S. de R. L. de C.V., Miguel G. Kramer #29, Col. Atlantida, Mexico D.F., MX 04370

Tel: +52 55 5689 8325

Fax: + 52 55 5689 8160

Canada: IRD Canada Limited 755 Jean-Baptiste-Varin, La Prairie, QC J5R6P3, Canada

Tel: (1) 450 724 4066

Fax: (1) 450 724 4077

Specifications are subject to change without prior notice.

(Rev 6: 19 May 2009)

Copyright © 2009 IRD LLC (IRD® Balancing). All rights reserved.

Part Number E51275